

Replacing the Cypress CY14U256LA-BA35 nvSRAM with Everspin's MR256DL08BMA45 MRAM

GENERAL CONSIDERATIONS for REPLACING nvSRAM with MRAM

Every write with an Everspin MRAM is instantly non-volatile for at least 20 years. There is no transfer of data from a volatile to a non-volatile memory cell, no external capacitors or back up batteries. The elimination of external components and highly reliable data retention make the Everspin MRAM a viable candidate for replacing the Cypress CY14U256LA-BA35 nvSRAM without compromising system performance.

EVERSPIN MRAM MEMORY

Everspin is the global leader in commercially viable MRAM technology and Everspin MRAM products are present in hundreds of applications demanding high-speed, reliable, non-volatile memory.

MR256DL08B COMPARISON TO CY14U256LA

The Everspin MRAM solution provides:

- Always Non-Volatile. No Unreliable Capacitor Dependent Backup Cycles
- No V_{CAP} or V_{BATT} required
- Immediate (<1ns) Power-off with no loss of data
- No complex Software STORE/RECALL routines
- Fast Start-up time (2ms vs. 20ms)
- Unlimited Read and Write cycles - No Wear-out Concerns
- 20-Year Data Retention with No Cycling Dependence
- Fewer components means smaller design footprint and lower total BOM cost
- Directly replaces the Cypress nvSRAM

COMPATIBILITY

The Everspin MR256DL08BMA45 MRAM memory is pin compatible with the Cypress CY14U256LA-BA35 nvSRAM.

WRITE/PROGRAM ENDURANCE

Unlike the 1 million storage cycle limitation of nvSRAM endurance, Everspin's MRAM has unlimited WRITE/PROGRAM endurance. This eliminates the concern of prematurely wearing out the device thereby limiting the lifecycle of the product in which the nvSRAM is used.

TIMING COMPATIBILITY

The Everspin MRAM and nvSRAM have standard, compatible asynchronous SRAM timing. Note that the MRAM has 45 ns read/write cycle time and the nvSRAM has 35ns timing. The MRAM retains data even at power off for an indefinite period of time over a wide temperature range.

It is important to note that the Everspin MR256DL08BMA45 device requires a minimum of 12ns hold time from Write Enable (and Chip Enable) high to Address invalid (Please see T_{WHAX} and T_{EHAX} in the MR256DL08B data sheet available [here](#).) Most microprocessors can accommodate this Hold time.

PIN COMPATIBILITY

- 256Kb organized in the 32Kx8 configuration
- 2.7 volt core/1.8V I/O operation
- Standard SRAM parallel address pins (A0-14)
- Standard byte-wide, bidirectional data pins (DQ0-7)
- Standard control signals (/E, /W, /G)

The MR256DL08B does not require an external capacitor and the other associated passive components required by the CY14U256LA-BA35 device.

The primary differences between the Cypress and Everspin devices are the two pins on the nvSRAM labeled: V_{CAP} and /HSB. These pins are used to support the nvSRAM backup cycle and are not required for operation of the MRAM.

V_{CAP} pin

A capacitor is required on the V_{CAP} ball (E3) on the nvSRAM. Everspin assigns a “Do not connect” (DC) to the corresponding ball on the MRAM. When replacing the Cypress nvSRAM with the Everspin MRAM, it is recommended that this ball be left floating. If a capacitor is connected to this ball, it is expected to have no effect on MRAM operation (assuming no initial charge on the capacitor).

/HSB pin

The /HSB ball (G2) of the nvSRAM is used to either initiate a Hardware Store or indicate a Hardware Store is in process. The corresponding ball on the MRAM is labeled as “Not connected (NC)”. Therefore, a host processor should not expect this I/O to be asserted in either direction (high or low) by the MRAM.

PINOUT DIFFERENCES

Figure 1 - Pin function comparison between MRAM and nvSRAM, 48-BGA package

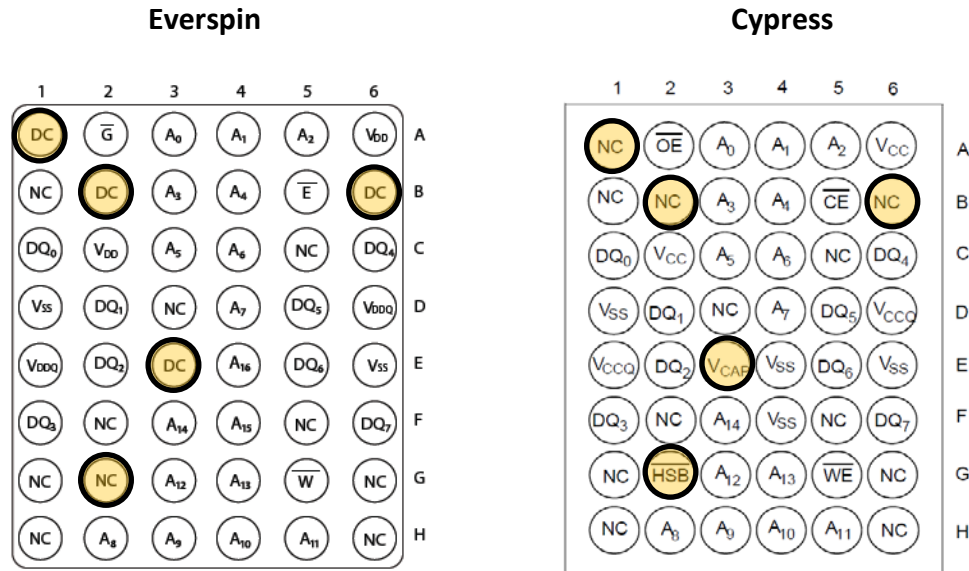

Figure 1 - Pin Function Comparison Between MRAM and nvSRAM, 48 FBGA Package

PIN #	Everspin	Cypress	Everspin connection	Everspin Comments
A1	DC	NC	Do not connect	Internally pulled down. Prefer to float but okay to tie to VIH or VIL
B2	DC	NC	Do not connect	Internally pulled down. Prefer to float but okay to tie to VIH or VIL
B6	DC	NC	Do not connect	Prefer to float but okay to tie to VIH or VIL
E3	DC	VCap	Do not connect	Must be kept at a Steady State. Prefer floating or tied to Vss to minimize current draw.
G2	NC	HSB_	No connect	Prefer to float but okay to tie to VIH or VIL

PACKAGE DIMENSIONS

The Everspin FBGA device is drop-in compatible with the corresponding Cypress equivalents. However, see Figures 2 and 3 to understand the package dimension

differences between the Cypress and Everspin FBGA packages. Make special note of the package dimension differences requiring different mechanical “Keep out” areas for these packages.

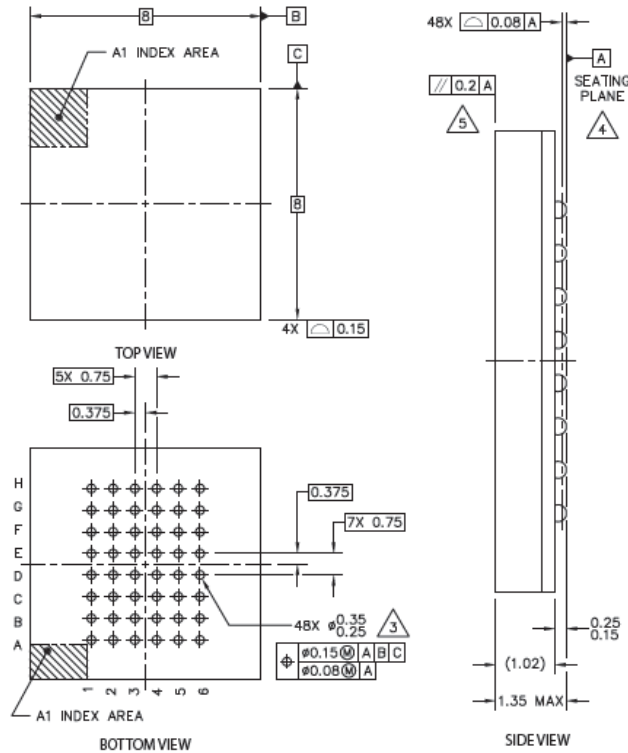

Figure 2 - Everspin FBGA Package Dimensions

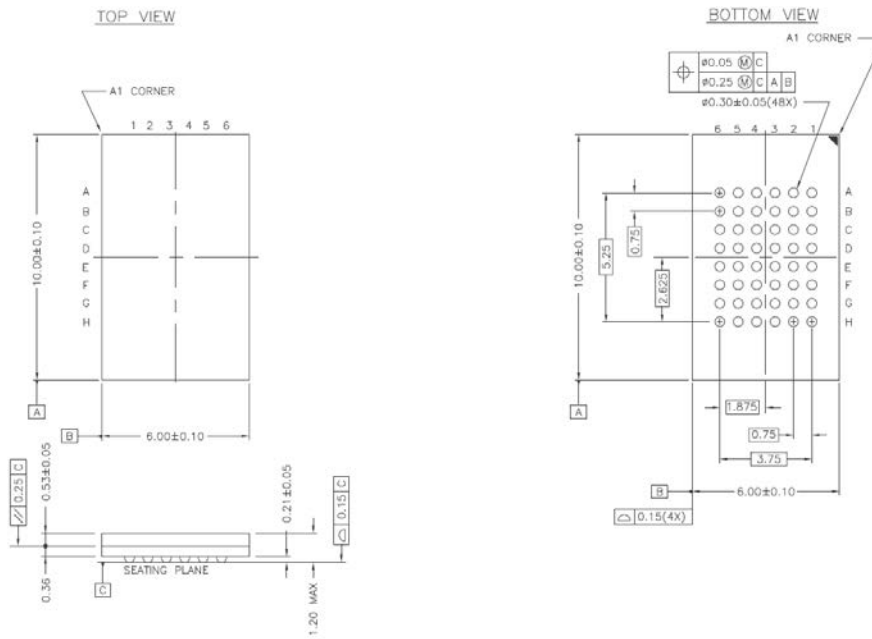

Figure 3 - Cypress FBGA Package Dimensions

OTHER REPLACEMENT DESIGN CONSIDERATIONS

HSB SOFTWARE

Due to its persistence, there is no power monitoring requirement for the Everspin MRAM as is the case with the nvSRAM. Therefore, initiating or monitoring Hardware Stores, Restores and associated software routines are unnecessary and can be eliminated.

SIMPLIFIED POWER CYCLING

When power is removed from the MRAM, data remains indefinitely over time and temperature until re-programmed. This feature, unique to MRAM, allows for Duty Cycle Power control enabling the user to reduce their overall power consumption without the concern of wear-out.

MRAM requires control signals /E and /W to track the power supply during power-up and be held high for a 2 ms start-up period a much shorter power-up requirement than the nvSRAM. When power fails, the Everspin MRAM simply inhibits write operations and no special power down timing considerations are needed since data is always non-volatile.

The nvSRAM device requires the /WE signal to track the power supply during power-up and be held high during the power-up recall period of 20 ms. The nvSRAM must sense the power failure, decouple the power supply from its backup capacitor, wait for any SRAM operations to complete, and then perform a parallel write to the EEPROM storage element during the 8 ms period after power has failed. This sequence is complicated by the fact that power falls at various ramp rates and in some cases bounces above and below the power supply threshold (brown outs) in rapid succession. Thus raising concerns about reliability of the backup storage cycle under all system power conditions including some that cannot easily be simulated or tested.

Additionally, there may be concern with the wear-out of nvSRAM EEPROM storage element which is limited to 1 million Program/Erase cycles. Everspin MRAM supports unlimited read, write, and power cycles. There are no wear-out concerns with MR256DL08Bxxx.

POWER-UP SEQUENCING

Both MRAM and nvSRAM will operate from a standard +3.3 volt power supply with +/-10% power supply range. Both MRAM and nvSRAM have similar standby and active operating currents, however, the "Start-up" time for the MRAM is 2ms vs. 20ms for the nvSRAM. Proper decoupling capacitors should be used to assure reliable operation.

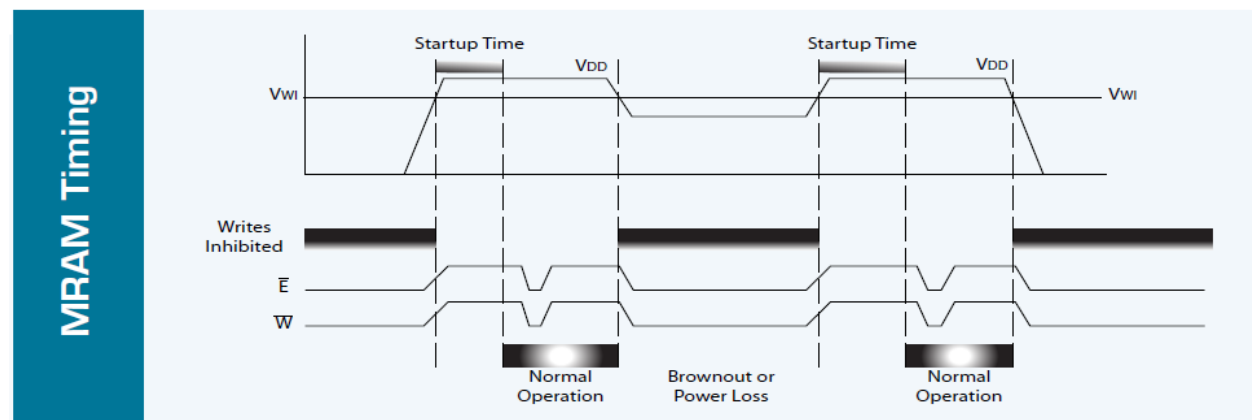
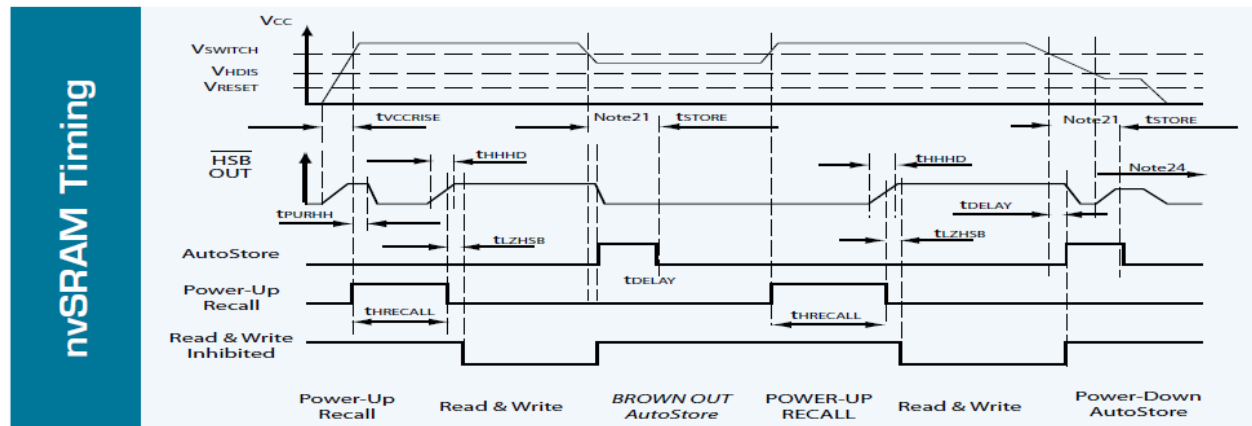

RELIABILITY CONSIDERATIONS FOR COMPARISON

CY14U256LA-BA35 uses conventional trapped charge technology for non-volatile storage. Data can leak away as wear-out results from temperature and excessive write cycles. Engineers must carefully design systems using nvSRAM to avoid exceeding the non-volatile write limitation of 1million cycles.

Everspin MRAM will provide the most cost-effective non-volatile RAM solution. The nvSRAM is constructed by combining a standard 6-transistor SRAM with a non-volatile EEPROM storage element in every cell. The total cell complexity is 12-transistors. MR256DL08BMA45 is built using a much simpler 1-transistor, 1-magnetic tunnel junction cell. The simple Everspin MRAM cell leads to improved manufacturing efficiency and increased reliability.

The reliability of an nvSRAM is dependent upon not only the memory chip but also the quality of the external V_{CAP} capacitor. Careful capacitor selection is necessary to assure reliable power sequencing.

MRAM uses magnetic tunnel junction technology for non-volatile storage. Data does not leak away at high temperature and there is no wear-out mechanism to limit the number of read, write, or power cycles. Data retention is better than 20 years at 125 °C.

How to Reach Us:

Home Page:
www.everspin.com

E-Mail:

support@everspin.com
orders@everspin.com
sales@everspin.com

USA/Canada/South and Central America

Everspin Technologies
1347 N. Alma School Road, Suite 220
Chandler, Arizona 85224
+1-877-347-MRAM (6726)
+1-480-347-1111

Europe, Middle East and Africa

support.europe@everspin.com

Japan

support.japan@everspin.com

Asia Pacific

support.asia@everspin.com

Everspin Technologies, Inc.

Information in this document is provided solely to enable system and software implementers to use Everspin Technologies products. There are no express or implied licenses granted hereunder to design or fabricate any integrated circuit or circuits based on the information in this document. Everspin Technologies reserves the right to make changes without further notice to any products herein. Everspin makes no warranty, representation or guarantee regarding the suitability of its products for any particular purpose, nor does Everspin Technologies assume any liability arising out of the application or use of any product or circuit, and specifically disclaims any and all liability, including without limitation consequential or incidental damages. "Typical" parameters, which may be provided in Everspin Technologies data sheets and/or specifications can and do vary in different applications and actual performance may vary over time. All operating parameters including "Typical" must be validated for each customer application by the customer's technical experts. Everspin Technologies does not convey any license under its patent rights nor the rights of others. Everspin Technologies products are not designed, intended, or authorized for use as components in systems intended for surgical implant into the body, or other applications intended to support or sustain life, or for any other application in which the failure of the Everspin Technologies product could create a situation where personal injury or death may occur. Should Buyer purchase or use Everspin Technologies products for any such unintended or unauthorized application, Buyer shall indemnify and hold Everspin Technologies and its officers, employees, subsidiaries, affiliates, and distributors harmless against all claims, costs, damages, and expenses, and reasonable attorney fees arising out of, directly or indirectly, any claim of personal injury or death associated with such unintended or unauthorized use, even if such claim alleges that Everspin Technologies was negligent regarding the design or manufacture of the part. Everspin™ and the Everspin logo are trademarks of Everspin Technologies, Inc. All other product or service names are the property of their respective owners.

©Everspin Technologies, Inc. 2014

Replacing the Cypress CY14U256LA-BA35 nvSRAM with Everspin's MR256DL08BMA45 MRAM

Author: Chuck Bohac, Manager Applications Engineering, Everspin Technologies chuck.bohac@everspin.com, 480-347-1161