

Replacing the Cypress CY62168EV30LL-45BVXI (2Mb x 8) MoBL SRAM with Everspin's MR4A08BMA35 MRAM

General Considerations for Replacing SRAM with MRAM

Everspin Toggle technology magnetic RAM (MRAM) is essentially non-volatile SRAM. Replacing SRAM with MRAM in any application adds non-volatility without compromise of performance or function. Replacing a non-volatile or battery-backed SRAM with MRAM will provide instant 20-year data retention without the overhead of storing data to a non-volatile cell or the expense and space of a battery backup power source.

Considerations for Replacing CY62168EV30LL-45BVXI (2Mb x 8) MoBL SRAM with Everspin's (2Mb x 8) MR4A08BMA35 MRAM

Designers considering a replacement of CY62168EV30LL-45BVXI with MR4A08BMA35 need to consider differences in package size and timing.

Table 1 – Overview: CY62168EV30LL-45BVXI vs. MR4A08BMA35

Parameter	CY62168EV30LL-45BVXI	MR4A08BMA35
Package		
Size and Height	6 x 8 x 1.0 mm	10 x 10 x 1.27 mm
Pinout / Footprint	See Figure 1 and Table 2 below	
Solder Profile	per JEDEC J-STD-020D.1	
Firmware / Timing	0ns Address Hold Time	12ns Minimum Address Hold Time. See Figure 2 below

Figure 1 – Pinout/Footprint Comparison and Considerations

6 x 8 Ball Grid Array, 0.75 mm Pitch

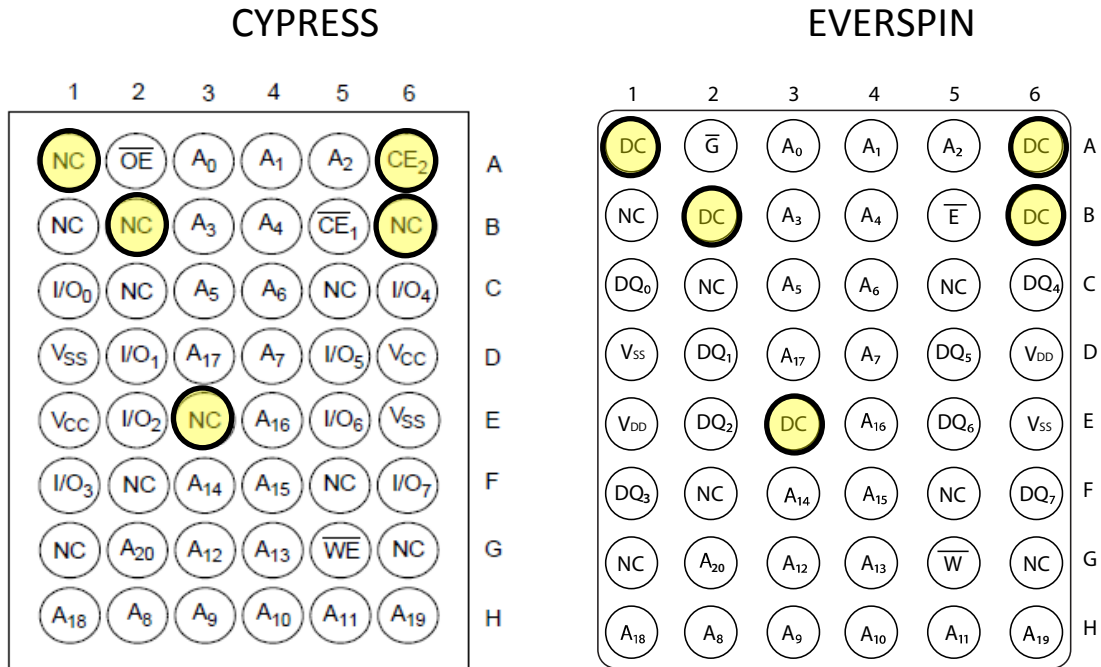

Table 2 – Pin Function Comparison

Ball #	Cypress	Everspin	Everspin Definition	Everspin Comments
A1	NC	DC	Do Not Connect	Prefer to float or pulled low
A6	CE#	DC	Do Not Connect	Function of CE2# is not available on the Everspin device. Prefer to float or pulled low.
B2	NC	DC	Do Not Connect	Prefer to float or pulled low
B6	NC	DC	Do Not Connect	Prefer to float or pulled low
E3	NC	DC	Do Not Connect	Prefer to float or pulled low

Circuit Design Recommendation for an MoBL SRAM and MRAM Compatible Layout

The recommended circuit design below will accommodate both the MoBL SRAM and MRAM with a single PCB layout.

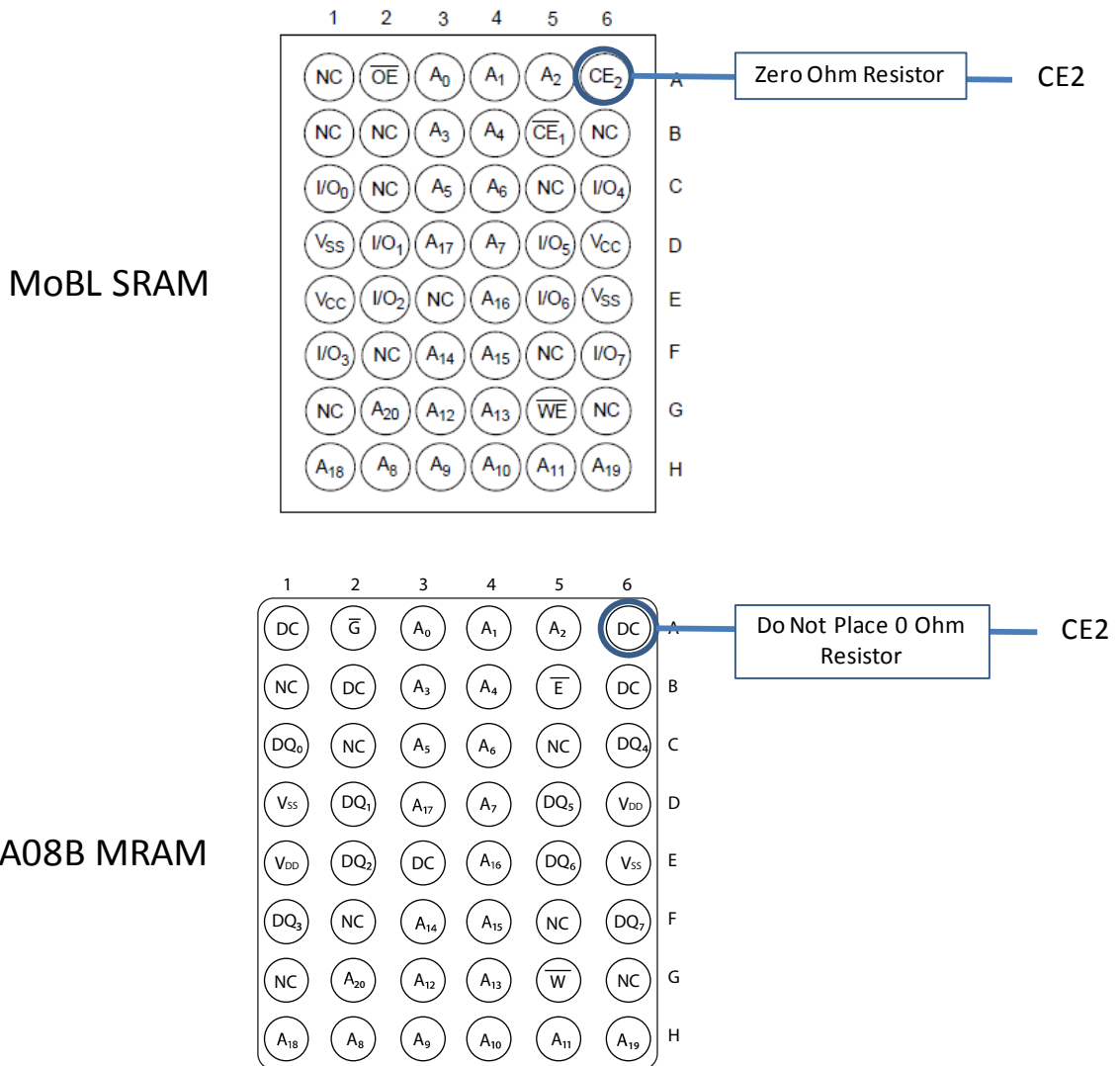
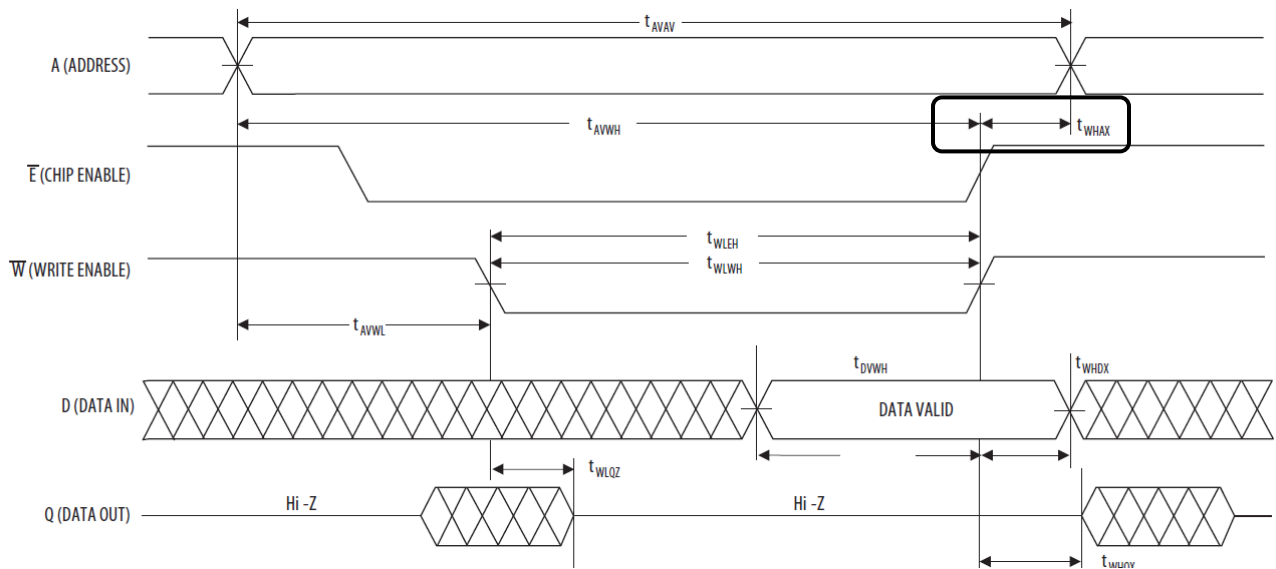

Figure 2 - 12ns Minimum for Address Hold Time for MR4A08B

The Address Hold Time (Everspin Write Recovery Time, t_{WHAX}) for the MR4A08B is a minimum of 12ns compared to 0ns minimum for CY62168EV30LL-45BVXI.



How to Reach Us:

Home Page:
www.everspin.com

E-Mail:

support@everspin.com
orders@everspin.com
sales@everspin.com

USA/Canada/South and Central America

Everspin Technologies
1347 N. Alma School Road, Suite 220
Chandler, Arizona 85224
+1-877-347-MRAM (6726)
+1-480-347-1111

Europe, Middle East and Africa

support.europe@everspin.com

Japan

support.japan@everspin.com

Asia Pacific

support.asia@everspin.com

Everspin Technologies, Inc.

Information in this document is provided solely to enable system and software implementers to use Everspin Technologies products. There are no express or implied licenses granted hereunder to design or fabricate any integrated circuit or circuits based on the information in this document. Everspin Technologies reserves the right to make changes without further notice to any products herein. Everspin makes no warranty, representation or guarantee regarding the suitability of its products for any particular purpose, nor does Everspin Technologies assume any liability arising out of the application or use of any product or circuit, and specifically disclaims any and all liability, including without limitation consequential or incidental damages. "Typical" parameters, which may be provided in Everspin Technologies data sheets and/or specifications can and do vary in different applications and actual performance may vary over time. All operating parameters including "Typical" must be validated for each customer application by `customer's technical experts. Everspin Technologies does not convey any license under its patent rights nor the rights of others. Everspin Technologies products are not designed, intended, or authorized for use as components in systems intended for surgical implant into the body, or other applications intended to support or sustain life, or for any other application in which the failure of the Everspin Technologies product could create a situation where personal injury or death may occur. Should Buyer purchase or use Everspin Technologies products for any such unintended or unauthorized application, Buyer shall indemnify and hold Everspin Technologies and its officers, employees, subsidiaries, affiliates, and distributors harmless against all claims, costs, damages, and expenses, and reasonable attorney fees arising out of, directly or indirectly, any claim of personal injury or death associated with such unintended or unauthorized use, even if such claim alleges that Everspin Technologies was negligent regarding the design or manufacture of the part. Everspin™ and the Everspin logo are trademarks of Everspin Technologies, Inc. All other product or service names are the

property of their respective owners.

Copyright © Everspin Technologies, Inc. 2013

Replacing the Cypress CY62168EV30LL-45BVXI MoBL SRAM with Everspin MR4A08B MRAM

Author: Chuck Bohac, Manager Applications Engineering, Everspin Technologies chuck.bohac@everspin.com, 480-347-1161